

## TTC

### TraceTek Sensing Module with Relay Contacts

The TraceTek TTC module offers a low cost option for liquid leak detection. It is designed for use with any TraceTek sensing cable, and can be integrated into a variety of monitoring systems. The TTC module includes three sets of relay contacts which can be used for remote annunciation and equipment control. A remote annunciation device is available.

#### Easy setup

All field wiring connections are easily made to a terminal strip molded into the base of the module. The module can be installed to reset automatically when the sensing cable dries following a leak, or to require a manual reset using the button provided. The TTC module includes adjustments for sensitivity to leaks, and

for the time delay before the leak alarm relay trips. These adjustments can be made in the field.

#### Versatile design

The TTC module provides separate relays for leak alarms and trouble alarms. The Leak relay has two sets of contacts so it can be used both to annunciate the alarm, and to provide direct control linkage to local devices. However, the system is not designed for constant switching applications. The Cable Break alarm monitors the integrity of sensing cable and jumper cable, and will trip if continuity is lost. This trouble relay is normally energized, so it will also signal if there is a loss of power.

The TTC module may be installed in non-hazardous indoor locations. Its small size allows for mounting in or on walls, or on DIN 1 rail systems.

#### Applications

The TTC is ideally suited to be simply integrated into centralized monitoring systems for large facilities. Typical applications include monitoring for leaks from individual pieces of equipment such as air-handling units, water-cooled machinery, single tanks, pumps, sumps, or other locations where a single length of TraceTek sensing cable is used.

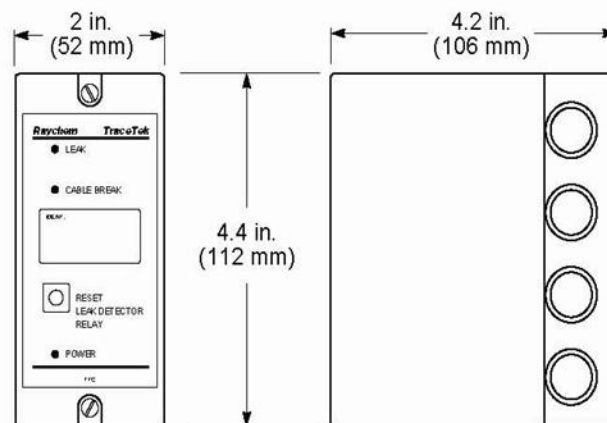
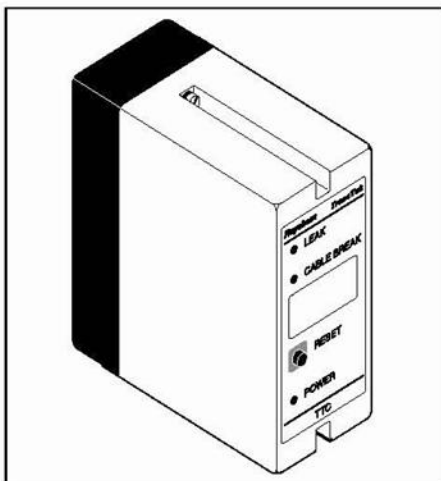

#### Technical Information

Sensing cable compatibility	All TraceTek sensing cables	
Max length of sensing cable (per channel)	100 ft (30 m)	
Temperature rating	32°F to 122°F (0°C to 50°C)	
Plastic enclosure	NEMA 1, IP 20	
Weight	0.77 lbs (0.35 kg)	
Power supply requirement (transformer not included)	12 to 24 Vac; 50/60 Hz	250 mA
	15 to 24 Vdc	150 mA
Terminal block wiring	14 AWG (max. 2.5 mm <sup>2</sup> )	
TraceTek jumper cable wiring	18 AWG (4 x 1 mm <sup>2</sup> )	
Relays	Leak	1 DPDT, Form C 5 A rating at 30 Vdc or 250 Vac
	Trouble	1 SPDT, Form C 5 A rating at 30 Vdc or 120 Vac Normally energized

#### Ordering Information

Catalog Number	Description
TTC-1	TTC alarm module with relay contacts
Accessories: TTE-XAL	External audible alarm
TTC-DRC	DIN 1 rail mounting clip

**Module Functions**

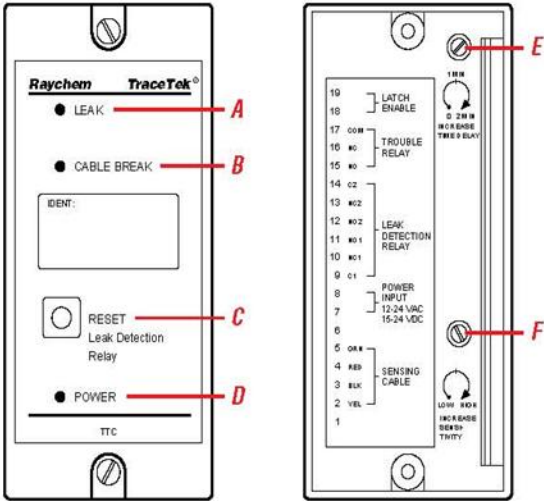

- A LEAK indicator (red LED)**  
Indicates system has detected a liquid leak.
- B CABLE BREAK indicator (yellow LED)**  
Indicates system has detected a break in the sensing cable.
- C RESET switch and indicator (red LED)**  
Indicates leak relay has been activated. Push to reset manually.
- D POWER monitor (green LED)**  
Indicates the system is on.
- E Adjusts time delay (0-2 minutes).**
- F Adjusts sensitivity.**

**Terminal Block Wiring**

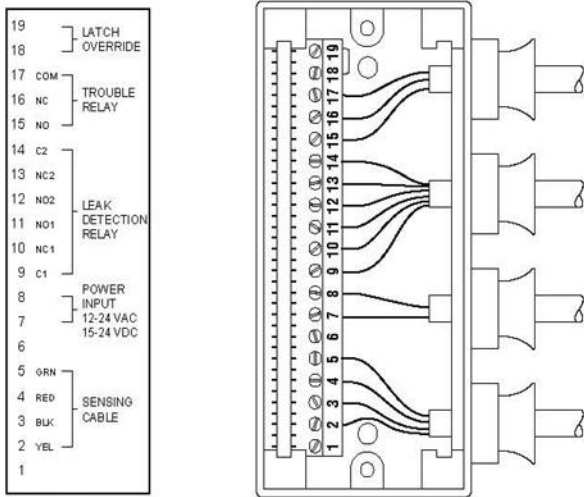

Typical configuration

- 18 – 19 Latch enable (Jumper enables alarm relay to latch.)\*
- 15 – 17 Trouble relay (SPDT)
- 9 – 14 Leak alarm relay (DPDT)
- 7 – 8 Power input, 12-24 volts AC or 15-24 volts DC
- 6 Open (Do not use.)
- 2 – 5 Sensing cable (2-yellow, 3-black, 4-red, 5-green)
- 1 Open (Do not use.)

\*Note: If jumper is removed, leak relay automatically resets when sensing cable dries

**Approval Information**



The TTC module is UL Listed and CSA Certified for use in ordinary areas.



The TraceTek products group is a part of Raychem Chemelex Division. Chemelex Division is ISO 9001 certified.



**3 Kent Road, Dagenham, Essex, RM10 8HA,  
United Kingdom**  
**Tel: +44 (0) 845 686 6066**  
**Fax: +44 (0) 845 686 6067**  
**Email: info@resikom.com**  
**Web: www.resikom.com**